

#### 規格說明 SPECIFICATION :

型式 MODEL	最高使用壓力 MAX. OPERATING PRESSURE kgf/cm <sup>2</sup>	壓力調整範圍 PRESSURE ADJ. RANGE kgf/cm <sup>2</sup>	最大流量 MAX. FLOW l/min	重量 WEIGHT kg
J-RVCA-※	350	A : 7-210	60	0.17
J-RVEA-※		B : 3.5-105	120	0.29
J-RVGA-※		C : 10-420 D : 2-60	240	0.64

#### 型號說明 HOW TO ORDER :

### J - RVCA - A - L - 10



單位UNIT : mm

## 安裝尺寸 INSTALLATION DIMENSIONS

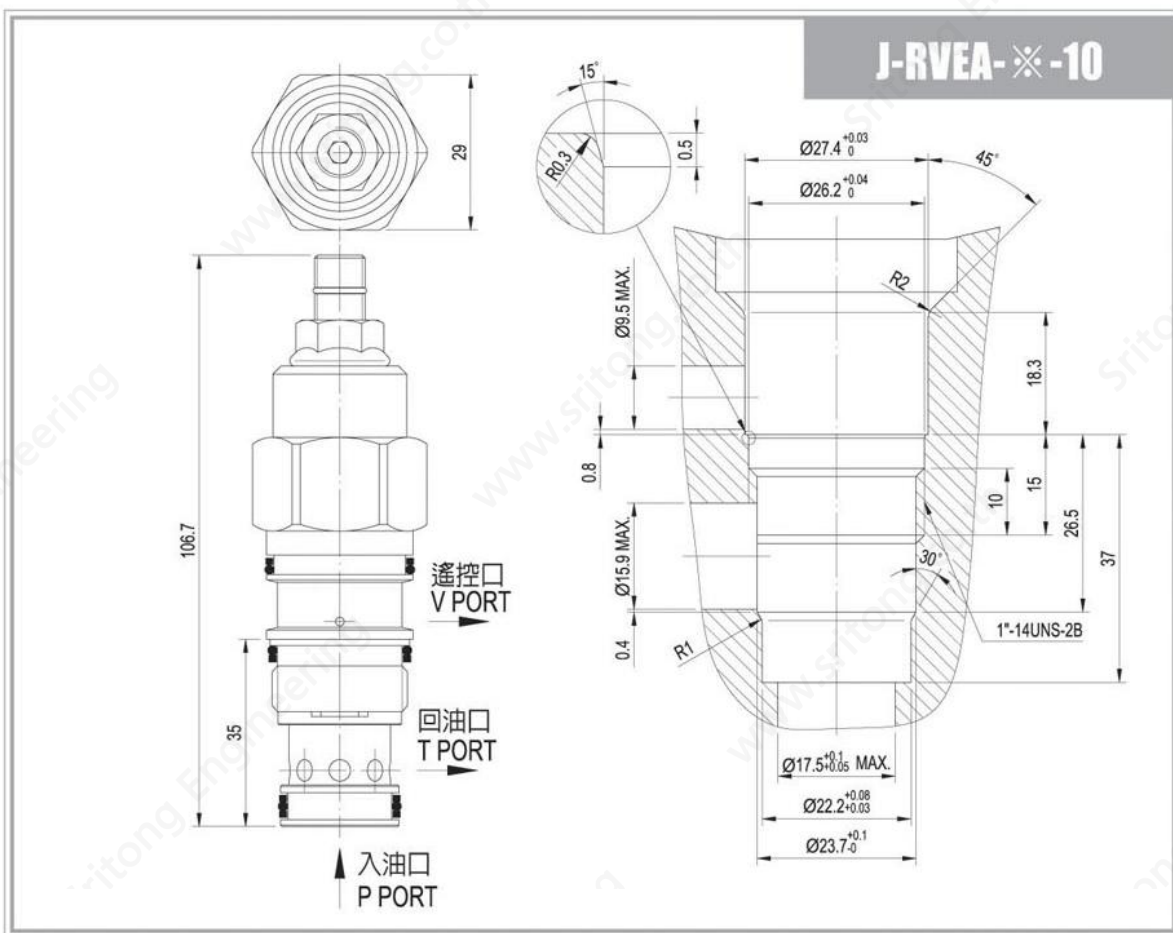
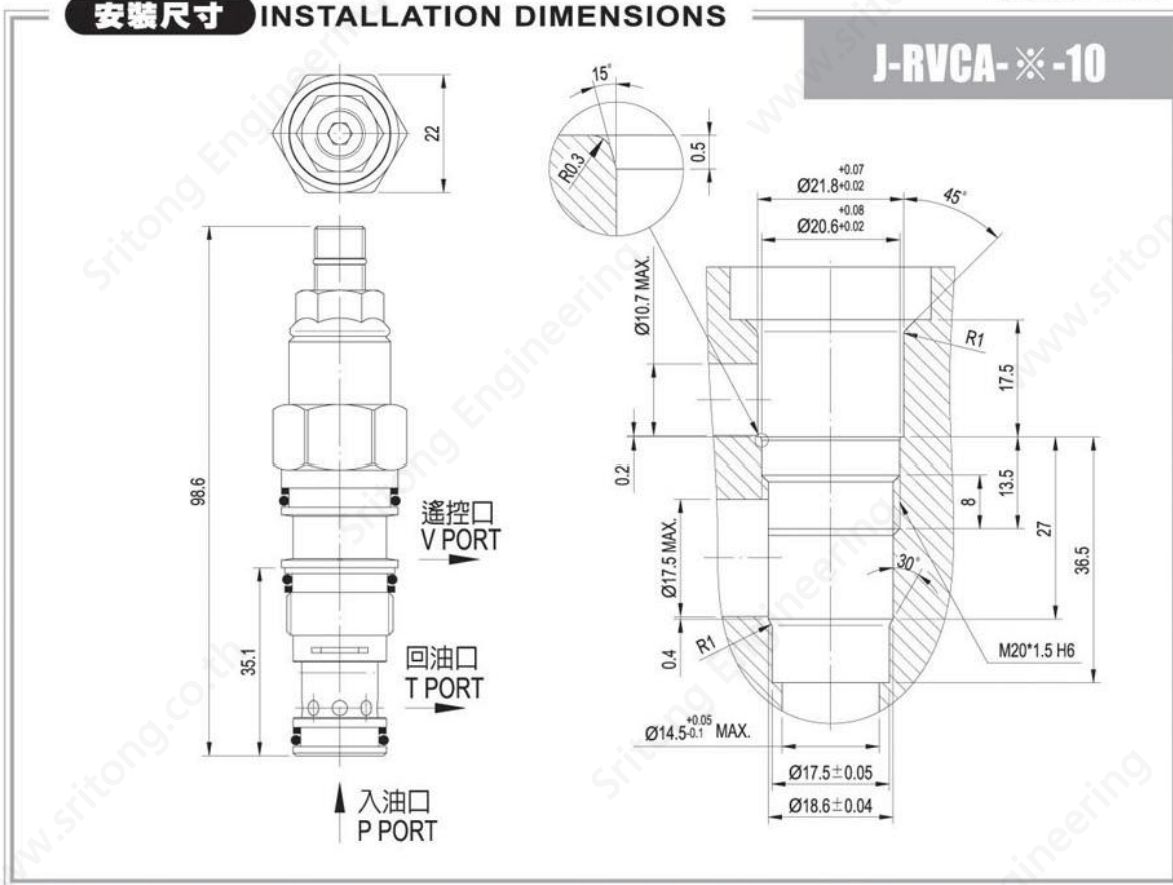

單位 UNIT : mm

### 安裝尺寸 INSTALLATION DIMENSIONS

## J-RVGA-※-10

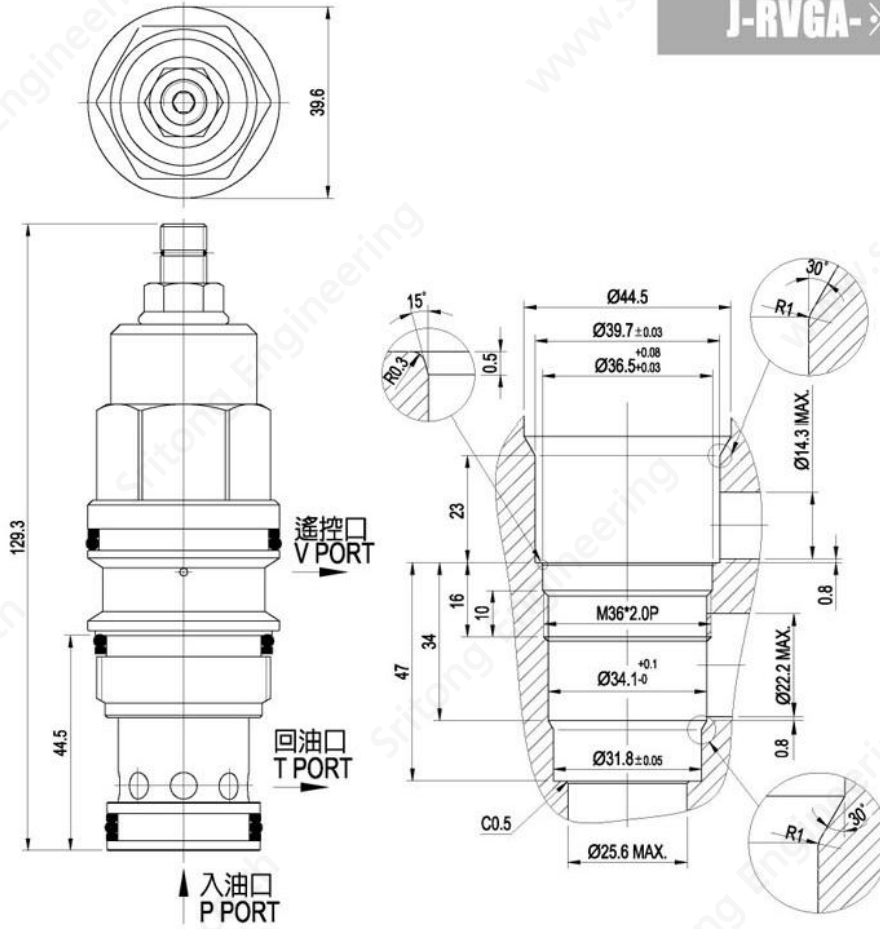

### 測試條件 PERFORMANCE CURVES

測試油黏度 TEST FLUID VISCOSITY : 35 cSt

測試油溫度 TEST TEMPERATURE : 50°C

流量-壓力特性 NOMINAL OVERRIDE

#### ● J-RVCA

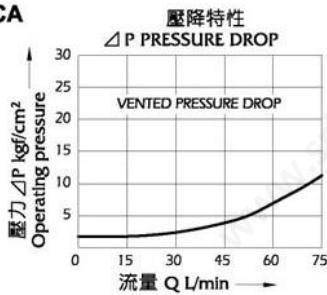

#### ● J-RVEA

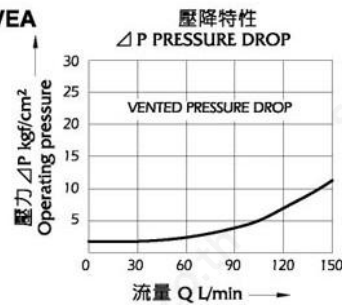

#### ● J-RVGA

